

ALTO

A V I A T I O N

Premium Cabin Audio/Entertainment Solutions
for all aircraft in Business Aviation™

BTT-400

Aircraft Bluetooth™ Audio Transmitter



The ALTO Bluetooth™ Audio Transmitter model BTT-400 allows the user to connect a Bluetooth™ Headset to the aircraft Cabin Entertainment System using the Bluetooth™ A2DP Profile. The compact enclosure has an internal antenna and supports simple mounting behind non-metallic side panel, in the PSU area, or in the seat armrest. Simple pairing supports a single switch and single indicator interface. The indicator illuminates when a connection is active. The paired headphone is automatically re-connected if power is cycled on the transmitter or the headphone. A press of the switch disconnects any connected headphone device, clears the pairing memory and waits for another connection.

Line level audio is received from a distribution unit from the cabin entertainment system and source selection is controlled externally. Volume control is on the BT headphone.

Multiple units can be installed to support varied seating positions.

Low latency headphones are preferred for optimized operation. Contact ALTO for recommendations.

FEATURES

- DO-160G Aviation qualified
- A2DP audio profile with SBC, APT-X, and APT-X Low Latency Codec integration
- <40mS Low Latency support insures perfect video-audio synchronization.
- Integrated high-sensitivity antenna, -90 dBm
- Discrete switch input and indicator output directly interfaces with ALTO CSS switch or any discrete switch & indicator
- Signal mixing for support of headphone jack
- Simple, reliable Bluetooth™ pairing and auto-reconnect
- Programmable connection naming
- Operates on 28VDC power supply
- Weighs less than 3.3 oz.
- Small enclosure for flexible mounting

SPECIFICATIONS

Product Code	107840-0400
Frequency Response	30-19kHz +/- 3dB
Power Supply	28VDC
Operating Current	30 mA maximum
Audio Output	Stereo analog input, Line Level, differential buffer
Transmit Power	+6.5 dBm
Codecs	Supports SBC, APT-X, AAC depending upon connecting device
Dimensions	1.7"W x 2.7"L x 0.75"H (44mmW x 69mmL x 19mmH)
Weight	< 3.3 oz. / 94 g

86 Leominster Rd Sterling, MA 01564
978-466-5992, 800-814-0123 (Toll-Free)
978-466-5996
www.altoaviation.com

ALTO products are continually improved. All specifications are subject to change without notice. Information in this document is proprietary.
Copyright © ALTO Technologies Corporation. All rights reserved. Doc# 107840-0400DS Rev 2

BTT-400 Aircraft Bluetooth™ Audio Transmitter

ALTO

AVIATION

Premium Cabin Audio/Entertainment Solutions
for all aircraft in Business Aviation™

BTT-400

Aircraft Bluetooth™
Audio Transmitter

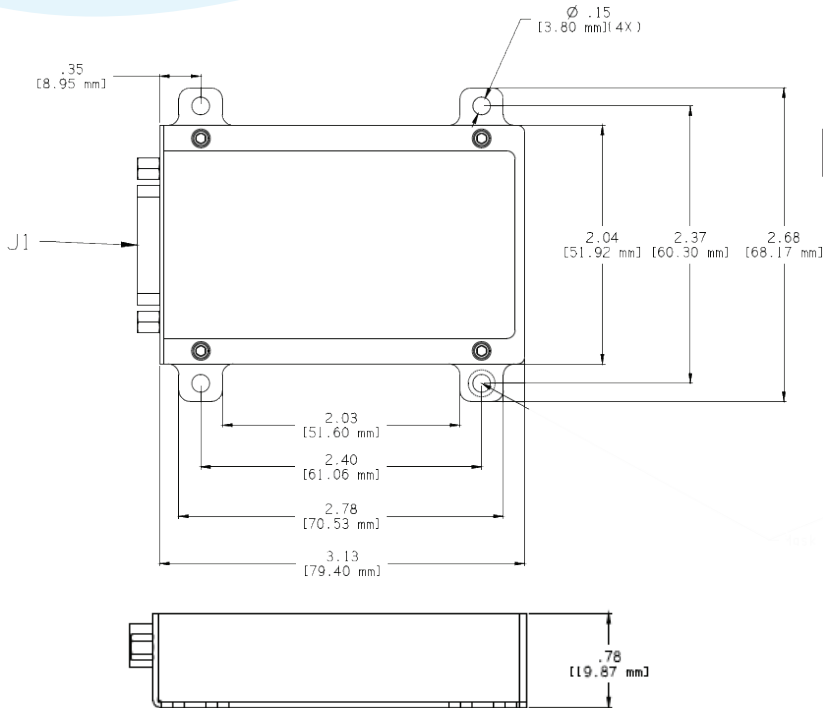

DIMENSIONS

CONNECTOR

Connector J1

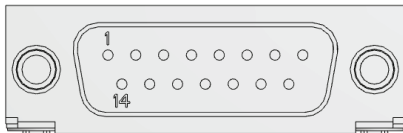

15 pin Male D-Sub with Fixed Female Jack Screws
Connector PN: TE 5747236-4 with Fixed Female Jack Screws
Mate: Any equivalent 15 Pin Female DSUB with Rotating 4-40 Jack Screws

Pin	Function	Pin	Function
1	Power +28V	9	Reserved
2	Power GND	10	Audio IN Left +
3	Pairing Switch 1	11	Reserved
4	Pairing LED	12	Audio IN Left -
5	Headphone L/R -	13	Reserved
6	Reserved	14	Audio IN Right +
7	Headphone R +	15	Audio IN Right -
8	Headphone L +		

BTT-400 Aircraft Bluetooth™ Audio Transmitter