

# ALTO

A V I A T I O N

Premium Cabin Audio/Entertainment Solutions  
for all aircraft in Business Aviation™

## P-12

Aircraft Page/Chime  
Loudspeaker 2.5" (57mm)



The P-12 is a small, high output loudspeaker for cockpit or cabin communication systems. Smooth frequency response eliminates the need for frequency equalization for superior intelligibility with voice paging.

### FEATURES

- Weighs <6.9 ounces
- 1.41" deep
- Integrated cable harness
- Small package allows for easy installation
- Smooth frequency response
- Superior intelligibility
- TSO-C139

### SPECIFICATIONS

<b>Product Code</b>	106509-012-4AXXXX (4 ohm) (Standard Connector type A) 106509-012-8AXXXX (8 ohm) (Standard Connector type A) 106509-012-4A0001 is a direct replacement for 106130-0004
<b>Frequency Response</b>	150Hz - 20KHz 4 or 8 ohm nominal
<b>Continuous Power Rating</b>	10 Watt RMS
<b>Max. Power Rating</b>	20 Watt RMS
<b>Sensitivity</b>	87 dB SPL @ 1W/1m @ 1kHz
<b>DO0160F Env. Cat</b>	[A2X]CAB[(SC)(HR)]XXXXXXXXBXXXXXXXX[XXXXX]XXXX
<b>Mating Connector</b>	2 pin Amp Universal MATE-N-LOCK on pigtail harness
<b>Weight</b>	<6.9 oz (<195g)
<b>Dimensions</b>	2.76"W X 2.76"H X 1.41"D 70.1mm W X 70.1mm H X 35.8mm D

# ALTO

## AVIATION

Premium Cabin Audio/Entertainment Solutions  
for all aircraft in Business Aviation™

### P-12

Aircraft Page/Chime Loudspeaker 2.5" (57mm)

P-12 Aircraft Page/Chime Loudspeaker 2.5" (57mm)

### DIMENSIONS

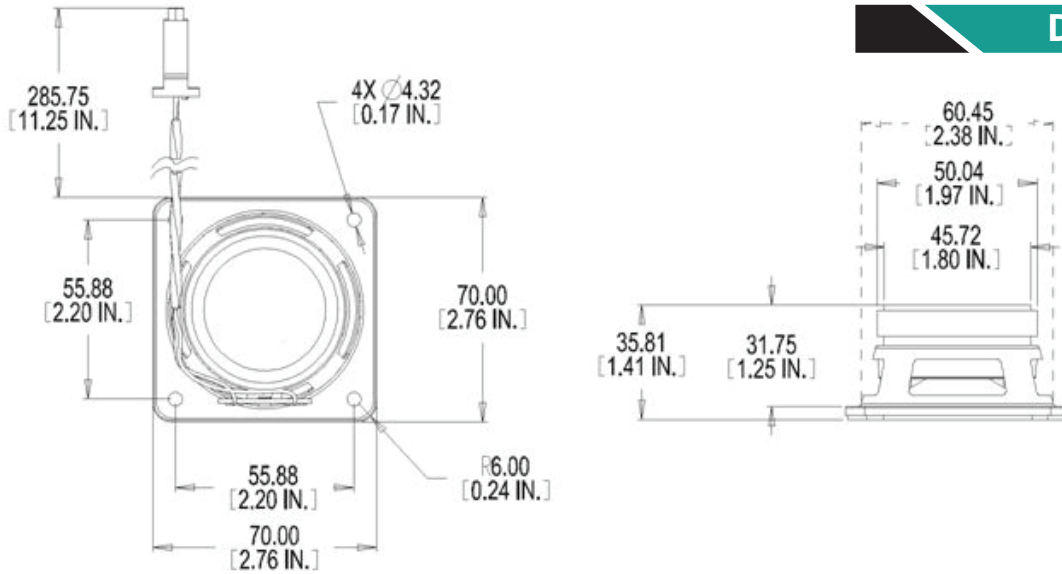

Note: Dimensions are for reference only. See DA (Delivered Assembly) drawing for exact dimensions. If the dimension, weight, and connector specifications of this product do not meet your requirements, ALTO can custom design a product for your application.

### MOUNTING OPTIONS

Figure 1 - Face Mounting (Recommended)

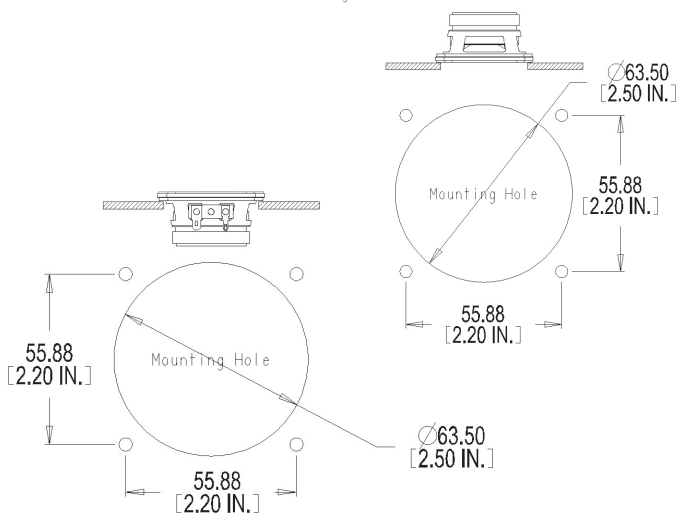

### CONNECTOR PINOUTS

Mating Connector : Amp PN 350778-1  
Mating Pin : Amp PN 350550-1

Pin 2 -  
Pin 1 +

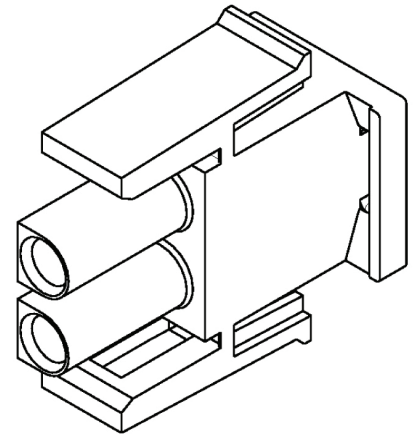

86 Leominster Rd Sterling, MA 01564  
978-466-5992, 800-814-0123 (Toll-Free)  
978-466-5996  
www.altoaviation.com

ALTO products are continually improved. All specifications are subject to change without notice. Information in this document is proprietary.  
Copyright © ALTO Technologies Corporation. All rights reserved. Doc# 106509-012-XAXXXXDS Rev 4