

ALTO

AVIATION

Premium Cabin Audio/Entertainment Solutions
for all aircraft in Business Aviation™

Aircraft Cabin Digital Entertainment AC Amplifier

DA-210AC



The ALTO DA-210AC is a TSO-C139 certified 8 X 40W / channel, Class D audio amplifier with integrated Digital Signal Processing (DSP). Designed to be used with most cabin management systems and paired with ALTO speakers and subwoofers, the amplifier will deliver a full spectrum of sound with unprecedented dynamics and clarity. DSP Equalization provides optimized sound for each specific aircraft interior. Each channel contains a distortion limiter circuit which allows for full power operation without harsh distortion. The low weight allows for convenient mounting and flexible system configuration. Optional ALTO nVELOP™ Digital Surround Sound is available to further enhance the cabin listening experience.

FEATURES

- Unit certified to TSO-C139
- 8 channels, 40 Watts RMS per channel Class D for very high efficiency with low heat output
- Integral EQ customized for each aircraft interior
- Advanced DSP including dynamic bass management, signal compression, spatial enhancement, Sinewatch™ distortion elimination
- Supports 2 independent audio zones
- Operates on 115VAC power supply
- Weighs under 4 Lbs.
- Small enclosure with forced air cooling for flexible mounting

SPECIFICATIONS

Product Code	106500-0210
Frequency Response	20Hz - 20KHz custom contoured to specific aircraft cabin
Power Supply	115VAC
Operating Current	Entertainment: 1 A idle, 3 A nominal, 15 A maximum
Audio Input	Entertainment: 4 channels of differential Analog
Output Power	40 Watts RMS/channel (320W) total
Output Load	4 - 8 Ohm recommended, 3 ohm minimum, Average impedance of all 8 channels must be >3.5 ohms
Distortion	<0.1% THD @ 50% rated power, maximum 3% (distortion limiter active)
Equalizers	Custom designed EQ/crossovers matched to aircraft cabin utilizing loudspeakers from the ALTO Aviation Entertainment System (AES) catalog
Dimensions	5.4"W x 3.7"H x 10.1"D (138mmW x 94mmH x 257mmD)
Weight	< 3.6 lbs / 1.64 kg
DO0160F Env. Cat. Main AC Amp	[A2X]CAB[(SC)(HR)]EXXXXZA(CF)[XXXI]AR(CF)ACTTM[XXE3X][XXXX]XAX

DA-210AC Digital Amplifier

ALTO

AVIATION

Premium Cabin Audio/Entertainment Solutions
for all aircraft in Business Aviation™

DA-210AC

Aircraft Cabin Digital
Entertainment AC Amplifier

DIMENSIONS

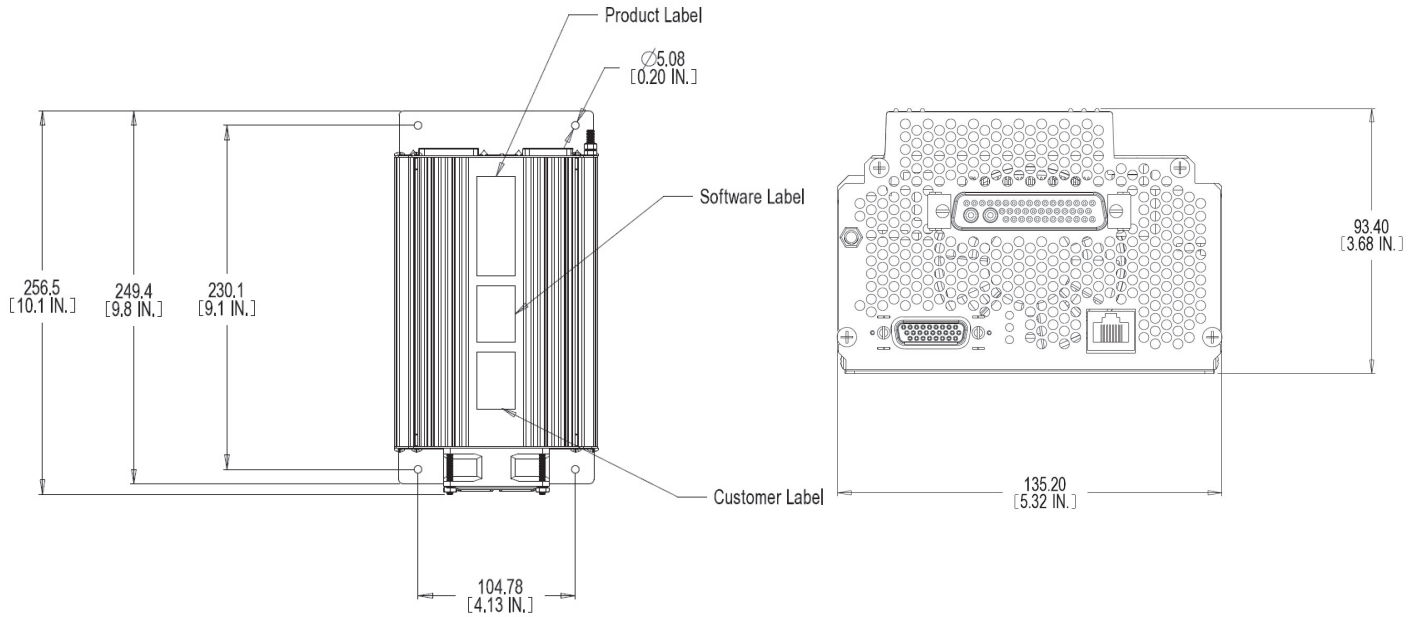

DA-210AC Digital Amplifier

CONNECTOR PINOUTS

J1 MAIN Connector

43W2 Combo D Male
Mating connector

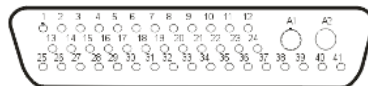

Positronic # CBD43W2M55B100V5X
Positronic # CBC43W2S110ANVL0/AA

J2 AUX Connector

26 pin D-sub Female
Mating connector

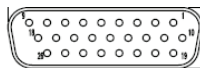

Positronic # ODD26F4B100V5X
Positronic # DD26M10ANVL0/AA