

The ASP-401 is a loudspeaker module with two high excursion drivers that are precisely matched to the acoustically tuned enclosure resulting in high output. It weighs less than 16 oz. The motor structure of the drivers is designed to have low magnetic leakage compared to conventional designs. The orientation of the two drivers provides for a wide sound dispersion characteristic reducing localization and an improvement in the acoustic balance in the aircraft cabin. The small dimensions of the unit simplify installation in the overhead panels, requiring less width and depth behind the panel, and a smaller grill opening into the cabin.



FEATURES

- Weighs < 16 oz
- 1.8" deep
- Small package allows for easy installation
- Wide dispersion pattern to reduce near-speaker localization while providing even sound throughout the cabin
- TSO-C139
- Integrated grills protect speakers during installation
- Aluminum enclosure with welded seams
- Integral part of the Alto Aviation Entertainment System (AES)

SPECIFICATIONS

- Product Code 106508-401-4AXXXX (4 Ohm) (Standard connector type A)
106508-401-8AXXXX (8 Ohm) (Standard connector type A)
- Frequency Response 150Hz - 20KHz
- Impedance 4 or 8 depending on application
- Drivers 2" high excursion, low magnetic leakage
2 per enclosure
- Enclosure Aluminum with welded seams,
Integral grill for driver protection during installation
- Continuous Power Rating 20 Watt RMS
- Max. Power Rating 40 Watt RMS
- Sensitivity 90 dB SPL @ 1W/1m @ 1kHz
- DO-160F Env. Cat [A2X]CAB[(SC)(HR)]XXXXXXBXXXXXX[XXXXX]XXXX
- Mating Connector See Connector Pinouts
- Weight < 16 oz (454 g)
- Dimensions 10.13"W X 5.7"H X 1.77"D
257.2mm W X 144.8mm H X 45mm D

Aircraft Cabin Loudspeaker

ASP-401



DIMENSIONS

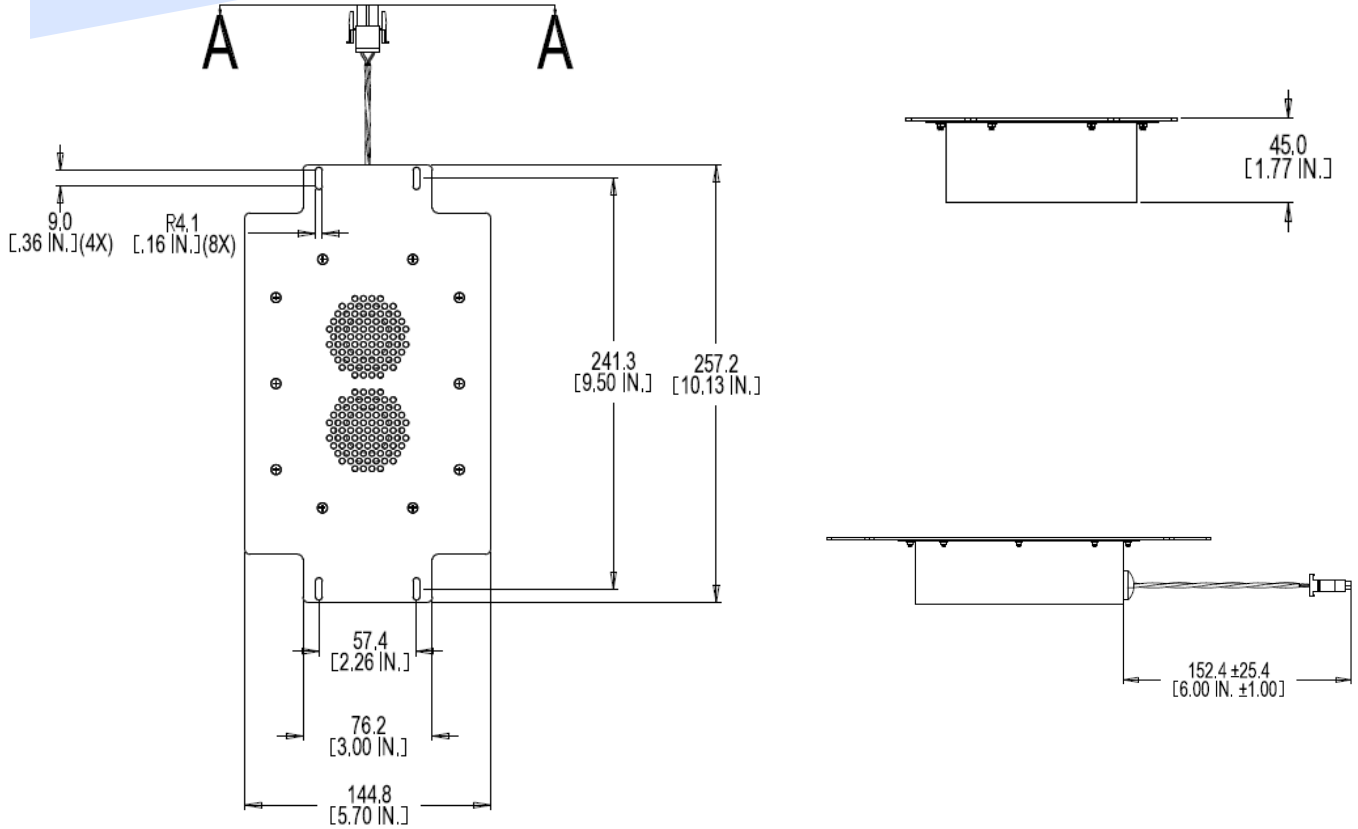

Note: Dimensions are for reference only. See DA (Delivered Assembly) drawing for exact dimensions.

If the dimension, weight, and connector specifications of this product do not meet your requirements, Alto can custom design a product for your application.

CONNECTOR PINOUTS

Connector for p/n's 106508-401-XAXXXX, where "A" designates specific connector. Please contact Alto for additional connector options

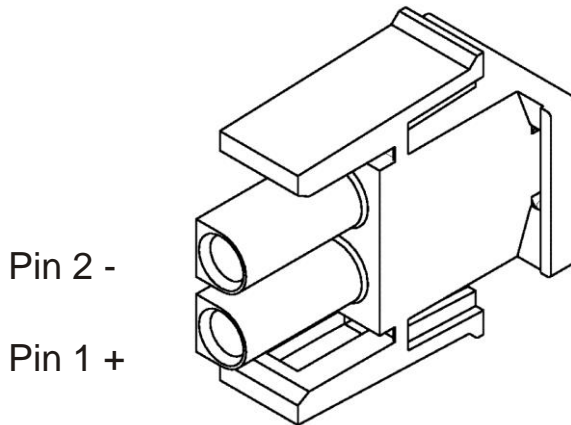

Mating Connector
Amp PN 350778-1

Mating Pin
Amp PN 350550-1

Alto Aviation 86 Leominster Rd PO Box 399 Sterling, MA 01564
Phone: 978-466-5992 Toll Free 800-814-0123 Fax 978-466-5996

www.altoaviation.com

Alto products are continually improved, all specifications are subject to change without notice. Information in this document is proprietary.

Copyright© Alto Technologies Corporation. All rights reserved. Doc# 106508-401-XAXXXXDS Rev 2 Page 2 of 2