

The ASP-375 is the lightest premium surround speaker enclosure available in the aviation market. At only 6.5oz, this speaker provides superior surround sound with little impact to the weight of the aircraft. The motor structure of the drivers is designed to have low magnetic leakage compared to conventional designs. The small dimensions of the unit simplify installation in the overhead panels, requiring less width and depth behind the panel, and a smaller grill opening into the cabin.

FEATURES

- Weighs only 6.5 ounces
- Only 1.5" deep
- Small package allows for easy installation
- Wide dispersion pattern provides even sound throughout the cabin
- Integrated grills protect speakers during installation
- Sealed aluminum enclosure with welded seams
- Integral part of the Alto Aviation Entertainment System (AES)

SPECIFICATIONS

- Product Code 106120-0001 Standard Configuration
- Frequency Response 200Hz - 20KHz
- Drivers 2.25" high excursion, low magnetic leakage
- Enclosure Sealed, Aluminum with welded seams
Integral grill for driver protection during installation
- Impedance 8 Ohm nominal
- Max. Power Rating 20 Watt RMS
- Sensitivity 89 dB SPL @ 1W/1m
- Storage Temp -40 to +80 C
- Operating Temp -20 to +60 C
- Dimensions 3.75"W X 3.75"H X 1.5"D
95.3mm W X 95.3mm H X 50.8mm D
- Mating Connector 2 pin Amp Universal MATE-N-LOK
- Weight 6.5 oz (0.2 kg)
- Wiring Requirements Min AWG 20 twisted pair

Aircraft Cabin Surround Speaker

ASP-375



DIMENSIONS

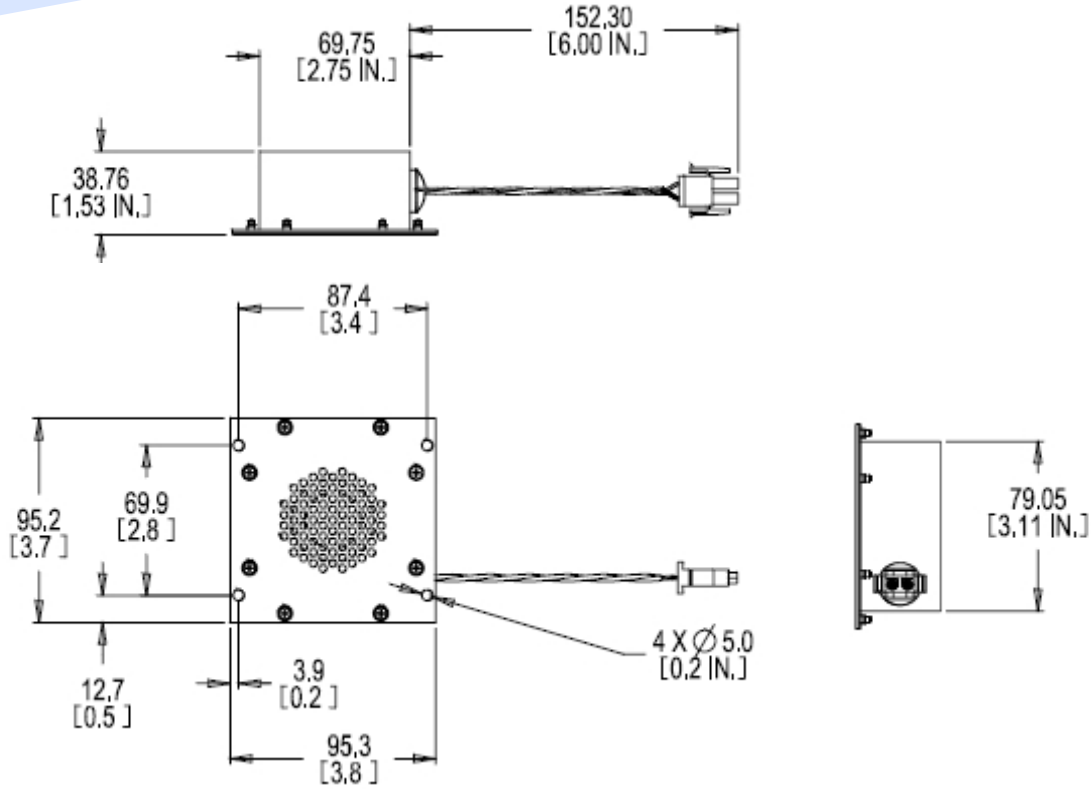

If the dimension, weight, and connector specifications of this product do not meet your requirements, Alto can custom design a product for your application.

CONNECTOR PINOUTS

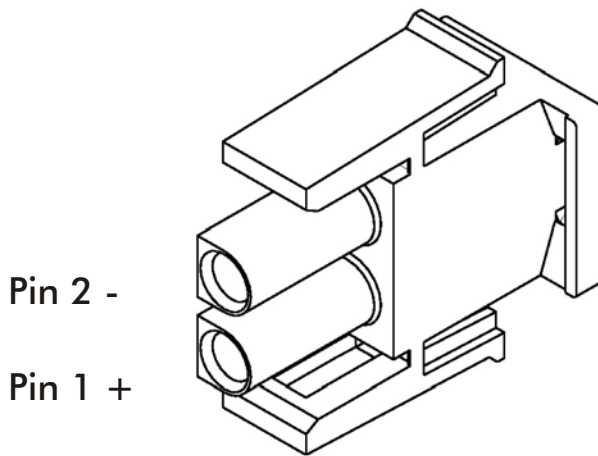

Mating Connector
Amp PN 1-480699-0

Mating Pin
Amp PN 350551-1