



The ASP-526 is the lightest premium loudspeaker enclosure available in the aviation market. At only 14oz, this is the first of its kind to be detailed in ounces rather than pounds. This dual driver, bass reflex loudspeaker module has two high excursion drivers that are precisely matched to the acoustically tuned enclosure resulting in high output. The motor structure of the drivers is designed to have low magnetic leakage compared to conventional designs. The orientation of the two drivers provides for a wide sound dispersion characteristic reducing localization and an improvement in the acoustic balance in the aircraft cabin. The small dimensions of the unit simplify installation in the overhead panels, requiring less width and depth behind the panel, and a smaller grill opening into the cabin.

FEATURES

- Weighs only 14 ounces
- Only 1.5" deep
- Small package allows for easy installation
- Wide dispersion pattern to reduce near-speaker localization while providing even sound throughout the cabin
- Integrated grills protect speakers during installation
- Bass reflex aluminum enclosure with welded seams
- Dual high efficiency drivers with low magnetic leakage
- Integral part of the Alto Aviation Entertainment System (AES)

SPECIFICATIONS

- Product Code 105985-0001 Standard Configuration
- Frequency Response 150Hz - 20KHz
- Drivers 2.25" high excursion, low magnetic leakage
2 per enclosure
- Enclosure Bass reflex matched precisely to the drivers
Aluminum with welded seams
Integral grill for driver protection during installation
- Impedance 4 or 8 Ohm nominal, depending on application
- Max. Power Rating 40 Watt RMS
- Sensitivity 90 dBSPL @ 1W/1m
- Storage Temp -40 to +80 C
- Operating Temp -20 to +60 C
- Dimensions 3.75"W X 7.25"H X 1.5"
95.3mm W X 184.2mm H X 50.8mm D
- Mating Connector 2 pin Amp Universal MATE-N-LOK
- Weight 14 oz (0.4 kg)
- Wiring Requirements Min AWG 18 twisted pair

Aircraft Cabin Loudspeaker

ASP-526



DIMENSIONS

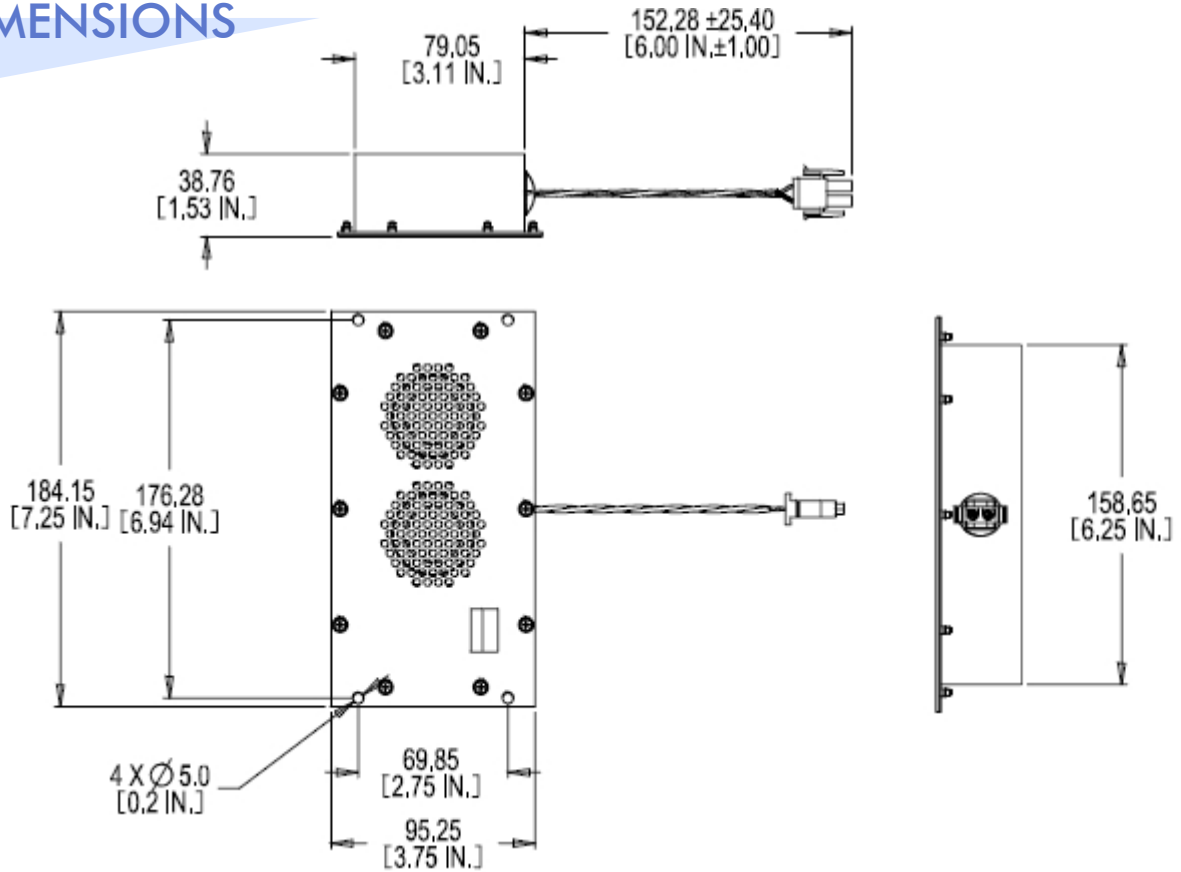

If the dimension, weight, and connector specifications of this product do not meet your requirements, Alto can custom design a product for your application.

CONNECTOR PINOUTS

Pin 2 -

Pin 1 +

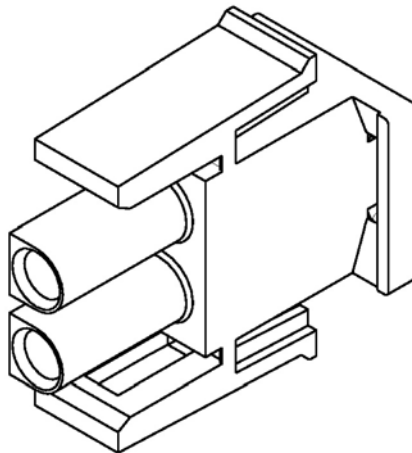

Mating Connector
Amp PN 1-480699-0

Mating Pin
Amp PN 350551-1