

Aircraft 4 Channel Digital Amplifier with Single Source Input

DX-130



The Alto Acapella Series DX-130 is a TSO-C139a certified amplifier for aircraft cabin loudspeakers. The unit has 4 channels with one stereo input with a discrete PA override feature. The amplifier has 4 independent audio power amplifier outputs supporting loudspeaker loads down to 4 ohms. The amplifier consists of a 4 X 40W / channel Class D audio amplifier stage. The integrated Digital Signal Processor contours the sound for perfect matching to the loudspeakers. The unit is fully configurable via a custom software interface to support numerous combinations of loudspeaker and PA override functions. This unit requires a variable input level for volume control. It is well suited for personal media devices with volume controlled output.

FEATURES

- Unit certified to TSO-C139a
- 4 channels, 40 Watts RMS per channel Class D for very high efficiency with low heat output
- Integral EQ customized for each aircraft interior
- Advanced DSP including dynamic bass management, signal compression, spatial enhancement, Sinewatch™ distortion elimination
- Supports one volume controlled input and speaker on/off via discrete logic
- PA Override feature with discrete ground select
- Operates on 28VDC power supply
- Weighs less than 2.0 lbs. (1 lbs. 15 oz.)
- Small enclosure with forced air cooling for flexible mounting

SPECIFICATIONS

- Product Code 106570-0130
- Frequency Response 20Hz - 20KHz custom contoured to specific aircraft cabin
- Power Supply 28VDC
- Operating Current 500 mA idle, 1 A nominal, 6 A maximum
- Audio Input Single stereo analog input, diff 44kohm input plus one Mic configurable as ground biased
All inputs accept line signal between 600mV and 4V RMS nominal
- Output Power 40 Watts RMS/channel (160W) total
- Output Load Loudspeaker: 4 - 8 Ohm recommended
Average impedance of all 4 channels must be >3.5 ohms
- Distortion <0.1% THD @ 50% rated power, maximum 3% (distortion limiter active)
- Equalizers Custom designed EQ/crossovers matched to aircraft cabin utilizing loudspeakers from the Alto Aviation Entertainment System (AES) catalog
- Dimensions 5.3"W x 1.7"H x 9.8"D (135mmW x 42mmH x 249mmD)
- Weight < 2.0 lbs / 0.9 kg
- DO-160G Env. Cat. [A2X]CAB[(SC)(HR)]EXXXFXZ[Z(RX)]AZ[AC][TT]M[XXE3X][XXXX]XAX

DX-130

DIMENSIONS

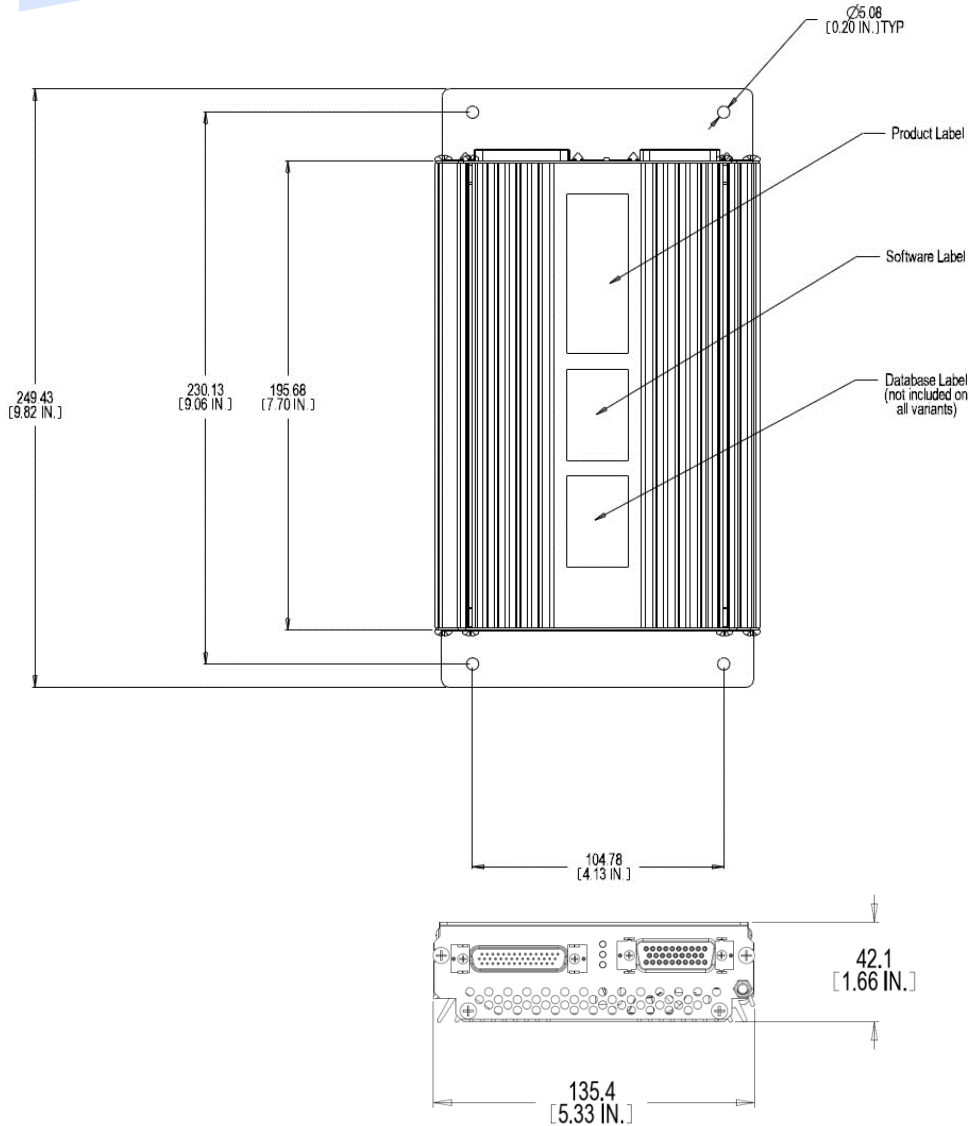

CONNECTORS

Signal Connector J4

44 pin Male Hi-Density D-Sub Mating connector

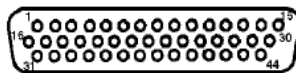

Positronic # ODD44M5B100V5X
Positronic # ODD44F10JVLX

Power Connector J5

29 pin Male Std-Density D-Sub Mating connector

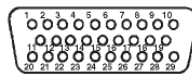

Positronic # MD29M5B100V5X
Positronic # RD29F10JVLX

Alto Aviation 86 Leominster Rd PO Box 399 Sterling, MA 01564
Phone: 978-466-5992 Toll Free 800-814-0123 Fax 978-466-5996

www.altoaviation.com